

Jet Scrubber Type I

General

Jet scrubbers are unique among gas scrubbers. They work on the injection principle and are the only scrubbers which produce an increase rather than a loss in pressure in the gas flow. Thus, when using a jet scrubber as a gas scrubber, there is generally no requirement for a mechanical ventilator for extracting and conveying the gases.

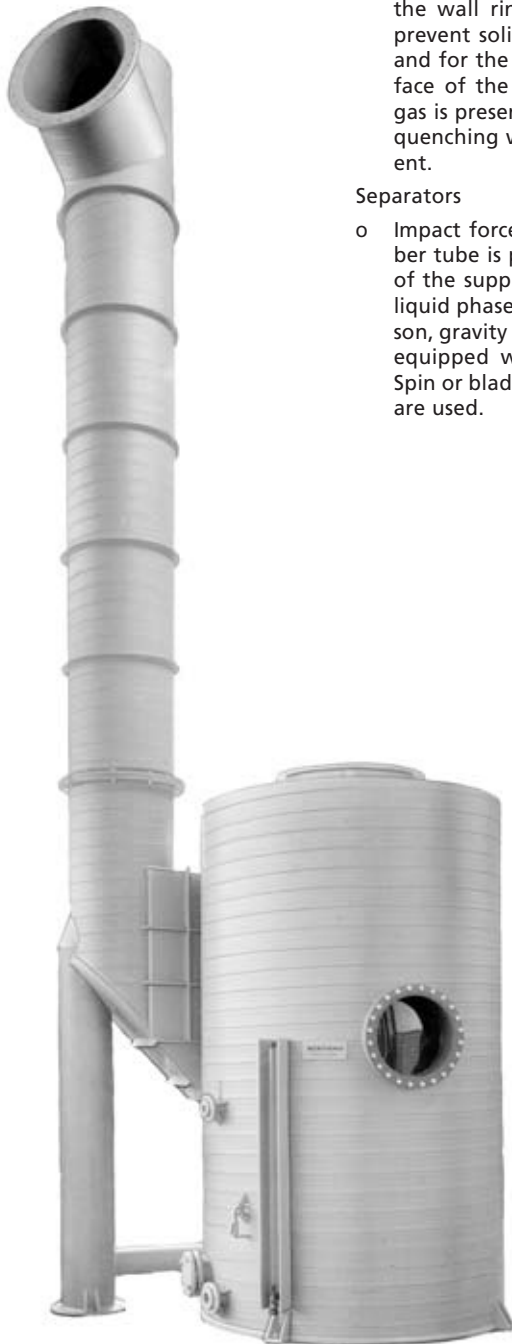

Fig. 1
Jet Scrubber Type I DN 700 with centrifugal separator completely from polypropylene (PP)

Design

The basic design of the jet scrubber type I consists of the scrubber tube with liquid distribution facility and motive nozzles as well as the separation and supply tanks. Both the scrubber tube and the separator can be easily modified and can therefore be optimally adapted to various duties.

Possible variations

Constructional design and possibilities for extension.

Scrubber tube

- o Horizontal and vertical gas inlet. · Rinsing ring at the vertical gas inlet to the wall rinsing process in order to prevent solids from being deposited, and for the cooling of the upper surface of the scrubber tube when hot gas is present. Flat jet nozzles for gas quenching when hot flue gas is present.

Separators

- o Impact force separator: The scrubber tube is positioned directly on top of the supply tank. Only the gas and liquid phase is separated. For this reason, gravity separators also have to be equipped with a droplet separator. Spin or blade separators or a demister are used.

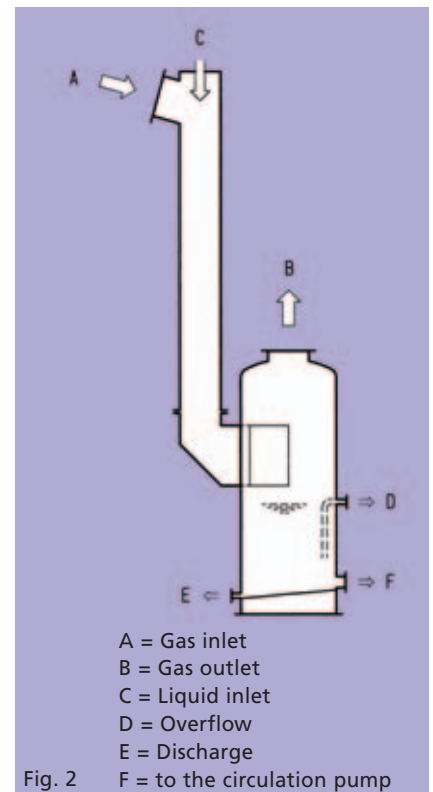

Fig. 2
F = to the circulation pump

- o Centrifugal separator: The scrubber tube is positioned directly on a mixing channel which turns the gas/liquid flow by 90° and feeds it tangentially into the separator and supply tank. This produces a spiral flow. On account of the centrifugal energy, the droplets reach the tank wall, from where they flow down into the liquid supply tank, while the gas, free of droplets, flows upwards. In most cases an additional droplet separator is not required. The centrifugal separator also prevents an extreme formation of foam during scrubbing processes where lye or other liquids with a tendency towards foaming are used. This constructional design allows either a counter-flow spray to be installed by lengthening the separator, or the jet scrubber to be extended by introducing a packed column or a tray column. There is also the possibility of installing an aerosol separation stage.

Materials

Complete jet scrubber plants of type I are available in the appropriate material for every requirement.

Plastics : thermoplastic with or without GRP reinforcement, as, for example PP, PE, PVC/GRP, PVDF/GRP

Steel: with or without corrosion protection, stainless steel and special materials such as titanium, Hastelloy etc.

Jet Scrubber Type I Standard version

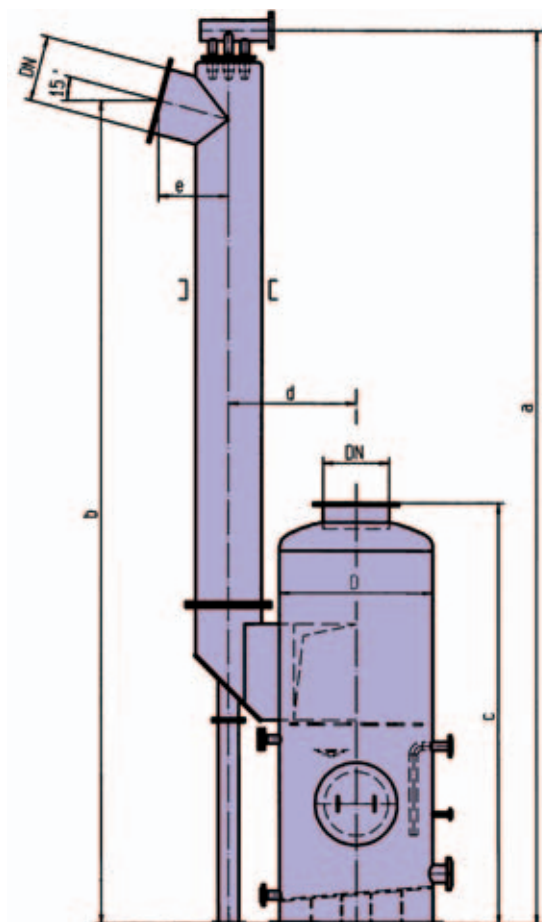

Fig. 3

Areas of application

- o Gas conveyance
- o Gas saturation and cooling
- o Hot gas quenching
- o Condensation
- o Separation of harmful substances (absorption)
- o Solids separation (de-dusting)

Advantages

- o Wide area of application
- o Auto-suction
- o No pressure loss
- o Can be flexibly combined and extended
- o Available in nearly all materials
- o Resistant to fouling
- o High level of reliability
- o Little maintenance

Suction flow, main connections and overall dimensions

Connection DN	Suction flow range in m ³ /h	Main dimensions in mm					
		D	a	b	c	d	e
100	100 - 300	400	3250	3000	1650	300	200
150	300 - 600	500	4000	3725	1950	450	250
200	600 - 1200	600	4600	4300	2100	470	300
250	1100 - 1800	700	4925	4600	2200	550	325
300	1600 - 2500	800	5325	4950	2400	650	375
350	2000 - 3500	900	5750	5375	2700	725	400
400	2700 - 4500	1000	6200	5800	2900	800	450
500	4000 - 7000	1200	6950	6450	3300	1000	500
600	7000 - 10000	1400	7400	6850	3600	1175	600
700	10000 - 14000	1600	7900	7250	3900	1425	700
800	14000 - 18000	1800	8450	7750	4300	1750	800
900	16000 - 23000	2000	8900	8150	4600	2000	900
1000	20000 - 28000	2200	9500	8650	5100	2150	1000

Larger plants on enquiry

Dimensions not binding

For all inquiries please use our questionnaire.